



Minipack-torre S.p.A.

Via Provinciale, 54 - 24044 Dalmine (BG) - Italy

Tel. (035) 563525 – Fax (035) 564945

E-mail: info@minipack-torre.it

<http://www.minipack-torre.it>



IT ISTRUZIONI PER L'INSTALLAZIONE, L'USO E LA MANUTENZIONE
EN INSTALLATION, OPERATION AND MAINTENANCE
DE INSTALLATIONS-, GEBRAUCHS- UND WARTUNGSANLEITUNG
FR INSTRUCTIONS POUR L'INSTALLATION, L'EMPLOI ET L'ENTRETIEN

IT MACCHINA CONFEZIONATRICE SOTTOVUOTO
EN VACUUM PACKING MACHINE
DE VAKUUMMASCHINE
FR MACHINE CONFECTIONNEUSE SOUS-VIDE

MV31 XP

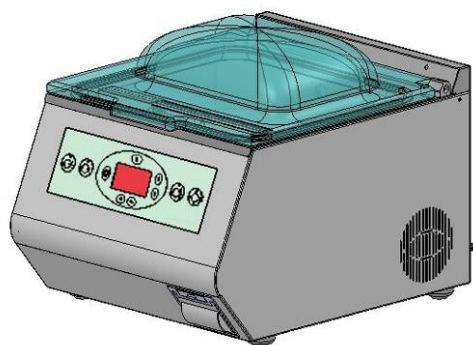

MV35 XP

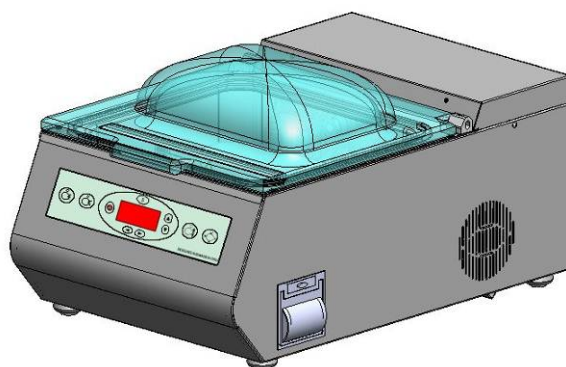

IT LEGGERE ATTENTAMENTE QUESTE ISTRUZIONI PRIMA DI USARE LA MACCHINA
EN BEFORE USING THE MACHINE PLEASE CAREFULLY READ THE INSTRUCTIONS
DE BITTE LESEN SIE DIESE ANLEITUNG GENAU DURCH, BEVOR SIE DIE MASCHINE BENÜTZEN
FR PRIERE DE LIRE ATTENTIVEMENT CE MANUEL D'INSTRUCTIONS AVANT D'UTILISER LA MACHINE

IT	Italiano	Pagina 01
EN	English	Page 21
DE	Deutsch	Seite 41
FR	Français	Page 61



DOC. N.FM111158
REV. 01
ED. 10.2013

TRANSLATION OF THE ORIGINAL INSTRUCTIONS



Index

EN

	Page
Chapter 1. Description	
1.1. Preface.....	22
1.2. Performances of packaging machine.....	22
1.3. Technical data of the machine.....	23
Chapter 2. Pouches features	
2.1. Pouches to use.....	24
Chapter 3. Machine usage conditions	
3.1. Items that may be packaged.....	24
3.2. Items not to be packed.....	24
Chapter 4. Safety standards	
4.1. Warnings.....	24
4.2. Description of safety stickers.....	26
4.3. Individual protection devices.....	26
Chapter 5. Machine installation	
5.1. Transport and positioning.....	26
5.2. Environmental conditions.....	26
5.3. Users.....	27
5.3.1. Loading the oil in the pump.....	27
5.3.2. Electrical connections.....	27
5.3.3. Gas connections.....	27
Chapter 6. Machine adjustment and setting up	
6.1. Adjustment.....	28
6.1.1. Control panel.....	28
6.1.2. Switching the machine on.....	28
6.1.3. Program selection and variable setting.....	29
6.1.3.1. Main display page (page one).....	29
6.1.3.2. Main display page(page two).....	30
6.1.3.3. CONFIGURATIONS display page.....	33
6.1.3.4. How to enter and modify text.....	35
6.1.3.5. Setting up label data.....	35
6.2. Packaging.....	36
6.3. Alarm messages.....	36
Chapter 7. Ordinary maintenance	
7.1. Precautions for ordinary maintenance interventions.....	37
7.2. Cleaning of the sealing bar.....	37
7.3. Replacement of the Teflon and the sealing blade.....	37
7.4. Replacement of the cover gasket.....	37
7.5. Cleaning machine.....	38
7.6. Vacuum pump maintenance.....	38
7.6.1. Condition Program.....	38
7.7. Problem solving.....	39
7.8. Wiring diagram.....	39
7.9. Pneumatic diagram.....	40
7.10. Disassembling, demolition and elimination of residuals.....	40
Chapter 8. Guarantee	
8.1. Certificate of guarantee.....	40
8.2. Guarantee conditions.....	40
CE declaration of conformity.....	81

1.1. Preface

This manual has been drawn up in compliance with the UNI 10893 standard dated July 2000. It is meant for all users in order to enable them to use the machine correctly. Keep it in a place which can be easily accessed in the proximity of the machine and which is known to all users. This manual is an integral part of the machine for safety reasons. We wish to specify the symbols in use here below in order to improve their understanding.

	ATTENTION: Accident prevention rules for the operator. This warning indicates the presence of dangers which can injure the person operating on the machine.
	ATTENTION: Hot parts. Shows the danger of burning, thus involving the risk of a serious accident for the exposed person.
	WARNING: It indicates the possibility of damaging the machine and/or its components.

All reproduction rights of this manual are reserved to the manufacturer. Partial or complete reproduction is forbidden as provided by the law. Descriptions and pictures provided in this manual are not binding. Therefore the manufacturer, reserves the right to make any change considered necessary. This manual cannot be transferred for viewing to third parties without authorisation in writing from the manufacturing company.

1.2. Performances of packaging machine

This machine represents what the modern technology of vacuum-packing may express at its best. It is flexible, easily programmable and cheap. It is intended to vacuum-pack foodstuffs by removing oxygen as well as any chemical and biological pollutant present in the environment. To attain the vacuum level you wish, just program the machine in order to remove almost all the air contained in the packet. Your product will preserve its organoleptic features, colour, taste, flavour and nutritive value for a long time.

In addition, this machine introduces an important innovation, an exclusive and revolutionary new concept for internal vacuum packaging: vacuum traceability on the packet.

This brand new feature, marketed exclusively by Minipack-Torre, can be used to produce one or more adhesive label (when packaging one or more bag simultaneously) displaying the essential product conservation information. It is possible to display a wide range of information, including: packing date, vacuum level, operator name/code, product name, % of inert gases present in the package, expiry date, packet number and the name of the company where the product was packed.

The information is customisable and can be set up easily using the electronic LCD interface.

1.3. Technical data of the machine

I = Electrical connections; H = Gas connection; R = Gas pressure reducer.

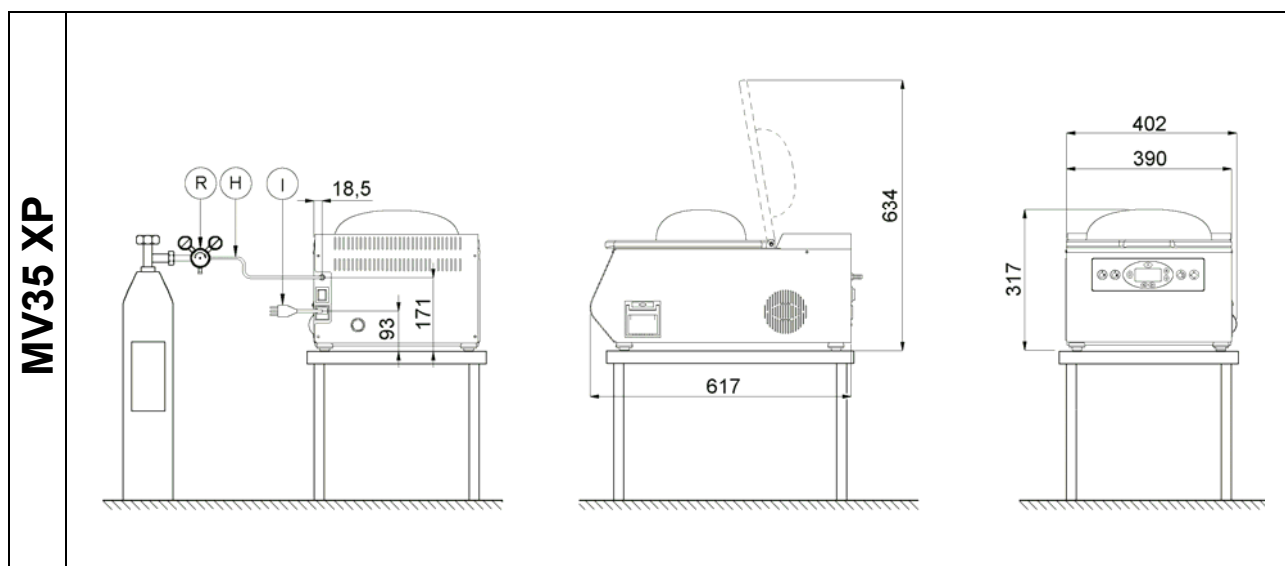
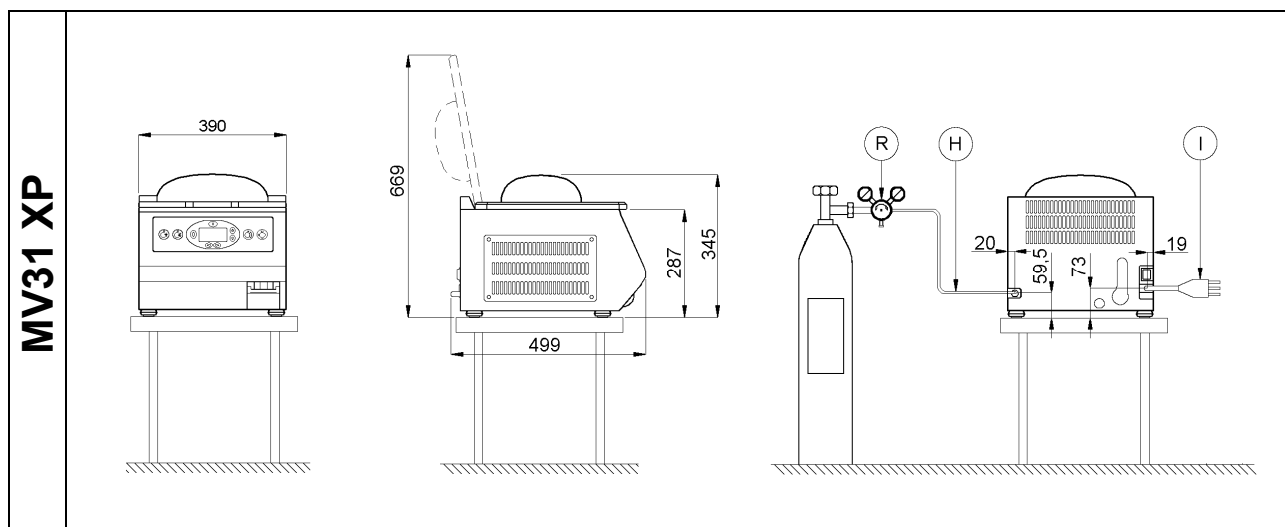

	MV31 XP	MV35 XP
Package sizes (mm)	610x520x420	710x460x485
Package weight (Kg)	41	53
Machine sizes with closed cover (mm)	390x499x345	402x617x317
Machine sizes with open cover (mm)	390x499x669	402x617x634
Machine weight (Kg)	37	45
Vacuum pump (m ³)	6	10

Chapter 2. Pouches features

EN

2.1. Pouches to use

They may be of different thickness (85÷200µm) and shall be both airtight and gastight. Only food packaging pouches can be used.

The following table indicates the maximum dimensions of the pouches that can be used with the various machine models.

Machine	Pouch width open side	Pouch length closed side
MV31 XP (front bar)	305mm	265mm
MV35 XP (front bar)	305mm	265mm

The following table indicates the min/max temperature limits the pouches can undergo to.

Type of pouch	Minimum temperature	Maximum temperature
for cooking	-15°C	+120°C for 30 minutes
for storage	-20°C	+70°C for 2 hours; +100°C for 15 minutes.



It is recommended to refer to the technical and safety sheets of the pouches in use and to observe the corresponding instructions!

Chapter 3. Machine usage conditions

EN

3.1. Items that may be packaged

This machine can be used to pack the majority of foodstuffs, including: fruit, fish products, dairy products, meat, delicatessen, oven ready products, gastronomic products, dried products, etc.

A more complete, although not exhaustive, list can be found in the table on page 30.

3.2. Items not to be packed

It is absolutely forbidden to pack the following products which might permanently damage the machine and harm operator:



- Liquids of any type and density in fragile containers
- Inflammable and explosive materials
- Gas bottles under pressure or of any type
- Bulk or volatile powders (unless a filter is assembled on the pump)
- Any material and product which might in any way cause the user to be in a dangerous situation and damage the machine.

Chapter 4. Safety standards

EN

4.1. Warnings

It is extremely important to read this entire chapter as it contains important information regarding risks that personnel are subject to in the event of incorrect use of the machine. These basic standards must be observed as well as specific standards applicable in the country of installation.

- The machine must be installed by trained and authorised technicians.
- This machine is not intended for use by persons (including children) with reduced physical, sensory or mental capabilities, or lack experience and knowledge, unless they have been given supervision or instruction concerning use of the machine by a person responsible for their safety.
- Children should be supervised to ensure that they do not play with the machine.
- Keep children and animals away from the machine when running. Do not allow children to play with the pouches.
- The machine must be used only for the purpose it was built for. Any other use shall be considered “improper” and therefore dangerous.
- Never allow unauthorised personnel to perform repairs or other operations on the machinery.
- The operator must be familiar with all warnings related to the tasks in hand and always be informed by the head of the site regarding risks.
- Ensure that all clothing is tight fitting, with particular reference to cuffs or other loose clothing.
- Ensure that all operating areas and transit zones are kept clear, clean and adequately lit at all times.
- Eliminate all safety hazard conditions before using the machine and always notify the head personnel of any malfunction.

- Never use the machine in the event of fault.
- Never tamper with safety devices or circuits.
- Never perform modifications on the machine without prior authorisation from the manufacturer.
- If the supply cord is damaged, it must be replaced by a special cord or assembly available from the manufacturer or its service agent.
- The electrical enclosure must remain closed during operation.
- Smoking is forbidden while the machine is operating!
- Never performs maintenance and/or adjustments to the machine during operation. Guards may only be disassembled by suitably trained and qualified maintenance engineers.
- Never operate the machine without all guards fitted. Ensure correct position of all guards before resuming normal operation.
- If it is necessary to leave the machine unattended, switch it off by turning the main switch to the "0" (OFF) position!
- The manufacturer declines all liability for damage or phisical injury caused by failure to observe safety standards.

THE MACHINE CAN NOT BE USED BY UNTRAINED PERSONNEL!

	During work pay attention to all hot parts of the machine. The temperature they can reach is so high that it can cause burns.
	Never use gaseous mixtures in presence of oxygen in a percentage higher than the atmospheric one (~ 19%).

Do not touch the sealing blade (16) immediately after sealing.
Danger of burns due to hot blade.

Do not seal if the sealing wire is broken.
Replace it immediately.

Do not touch the vacuum pump (23) just after a working cycle.
Possibility of burning due to the high temperature the pump may reach

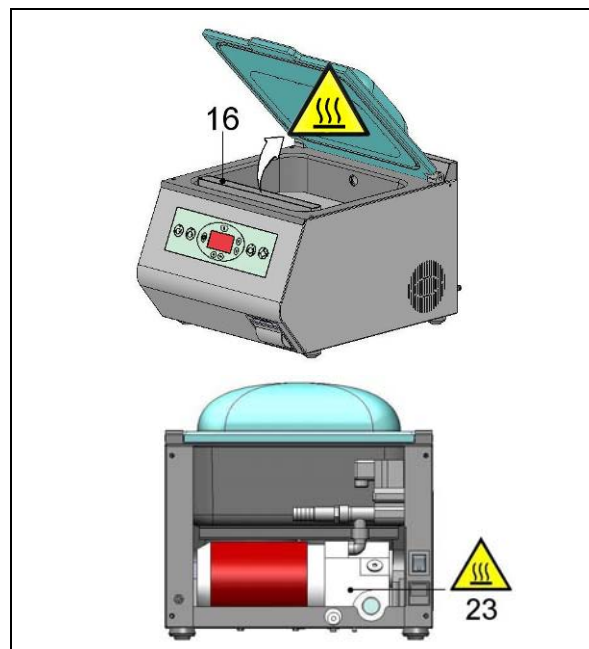

In case of a power failure during a working cycle when the cover is closed, do not use any tool in order to force its opening. Wait for the power supply to be restored.

Do not place any weight on the cover (18)!
 Prevent any object from falling on the cover!
 This can compromise the integrity, causing cracks or damage.

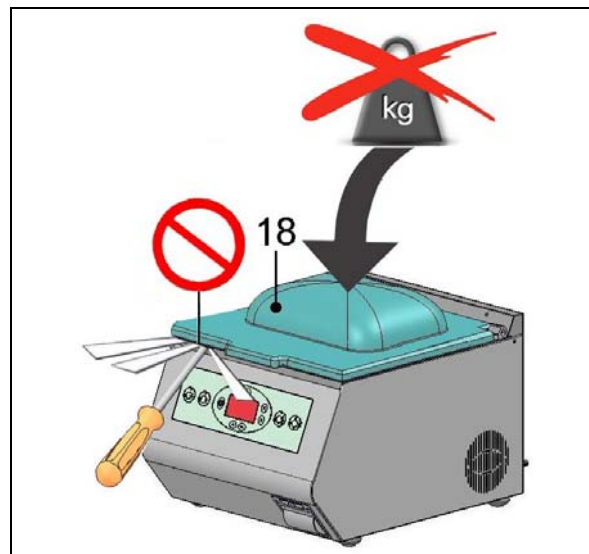

Do not proceed with packaging if the cover has cracks or is broken.

Replace it immediately.





4.2. Description of safety stickers

The following safety stickers feature on the machine:

	<ul style="list-style-type: none"> On the power input. <p>ATTENTION! Periodically check the correct insulation of the power cable and the integrity of the socket. During machine operation, the inspection panels to the electric system must be correctly fitted.</p>
	<ul style="list-style-type: none"> On the sealing bars positioned inside the tank On the vacuum pump positioned inside the machine. <p>ATTENTION! Hot members. It shows the danger of burning, thus involving the risk of a serious accident for the exposed person.</p>
<p>ATTENZIONE : Superficie calda. Evitare il contatto. WARNING : Hot surface. avoid contact. ATTENTION : Surface chauffante. Ne touchez pas.</p>	<ul style="list-style-type: none"> On the sealing bars positioned inside the tank <p>ATTENTION! Indicates the danger of burns with risk of accident in case of contact with the hot surface of the sealing bar.</p>
<p>ATTENZIONE : Per la pulizia del coperchio non utilizzare alcool o solventi ma esclusivamente acqua e sapone. WARNING : Do not use methylated spirits and solvents clean the lid, but water and soap only. ATTENTION : Pour le nettoyage du couvercle, ne pas utiliser ni alcool ni solvants. N'employer que de l'eau et savon.</p>	<ul style="list-style-type: none"> On the Plexiglas lid. <p>ATTENTION! Indicates how to clean the lid to prevent damaging it and reducing its transparency or strength.</p>

4.3. Individual protection devices

	<p>Wear safety shoes that protect feet from impacts, crushing and compression while moving or handling the machine.</p>
	<p>Wear safety gloves that protect the hands from crushing and mechanical hazards and while moving or handling the machine.</p>
	<p>Wear safety gloves that protect the hands against cutting risks while changing the sealing blades.</p>
	<p>Wear safety gloves that protect the hands against the specific risks associated with the materials to be packed (mechanical, chemical) and against coming into contact with the high temperatures present on the seals and/or sealing bars (up to 100°C).</p>
	<p>Wear safety gloves that prevent the hands from coming into contact with foodstuffs when packaging them.</p>

5.1. Transport and positioning

	<ul style="list-style-type: none"> When transporting and positioning the machine, it is recommended to handle it with great care! Neither overturn nor tilt the machine! Oil might come out of the pump and damage the machine.
---	---

Cut the strap with scissors make sure you protect your eyes by wearing glasses and withdraw the cardboard. Cut the strap fastening the machine to the pallet.

5.2. Environmental conditions

- Lift the machine and place it on the working surface. Make sure the machine is placed in a proper environment without any inflammable and explosive materials or gas. The machine may only be installed on smooth, flat non-inflammable surfaces.
- Leave a minimal space of 0,5m around the machine so that not to obstruct air outlets.

Working environmental conditions:

- Temperature from + 5°C to + 40°C.
- Relative humidity from 30% to 90%, without condensation.

The lighting of the operation room shall comply with the laws in force in the country where the machine is installed. However, it shall be uniform and provide for good visibility in order to safeguard the operator's safety and health.

MACHINE SAFETY FACTOR = IP20

THE AERIAL NOISE MADE BY THE MACHINE IS LOWER THAN 70 dB(A)

5.3. Users

5.3.1. Loading the oil in the pump

If the pump has no oil, to load, fully use the provided bottle.

The oil loading operation must be carried out by trained and authorised technical personnel.

To access inside the machine, remove the rear panel, using a screw driver to remove the fixing screws.

Remove the cap to load oil (21) using the provided wrench and fill the oil tank following the instructions indicated in the pump user manual attached to the machine.

- (20) Oil discharge plug
- (21) Oil filling plug
- (22) Oil inspection plug

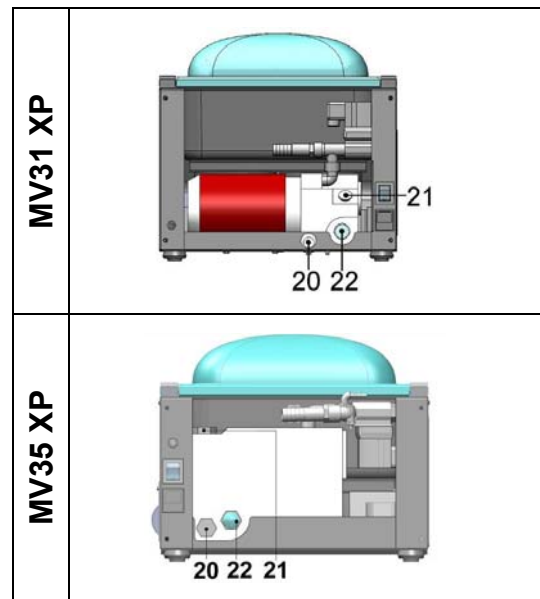

5.3.2. Electrical connections

Voltage (V): see data on plate

Frequency (Hz): see data on plate

Maximum absorbed power (W): see data on plate

Maximum absorbed current (A): see data on plate

Note: When contacting the Manufacturer, always indicate the model and the serial number specified on the plate on the rear part of the machine.

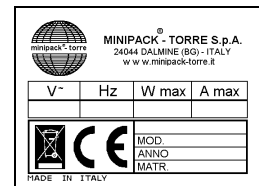

OBSERVE HEALTH AND SAFETY REGULATIONS!

If the machine is not equipped with the power supply plug, use a plug that is suitable for the voltage and amperage values described by the rating plate and that can comply with the rules in force in the installation country.

GROUNDING OF THE UNIT IS OBLIGATORY!

Before executing electrical connections, make sure the mains voltage matches the one on the plate on machine rear and that the ground contact complies with the safety rules in force. In case of doubts about the mains voltage, contact the local public supply Company.

Insert the plug on the cable from machine electrical cabinet in a mains power supply socket that can be reached easily by the operator.

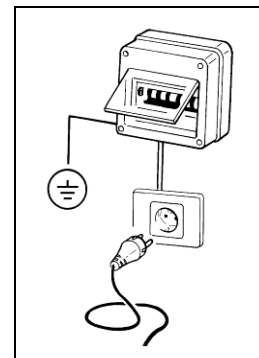

5.3.3. Gas connections

When carrying out packaging operations in modified atmospheres, use specific gas for food package in compliance with the rules in force about food additives in the country where the machine is used.

The gas, which consists of a mixture of nitrogen, carbon dioxide and, more rarely, oxygen and other gases, is a “made to measure” gaseous mixture, depending on the product to be packaged.

Never use gaseous mixtures in presence of oxygen in a percentage higher than the atmospheric one (~ 19%).

Connect gas attachment, in case the machine is equipped with such a device, to the gas cylinder through the proper tube (H) (see chapter 1.3.).

Pressure of gas plant has to be set on about 2 atm., bearing in mind the max. working pressure is 4 atm.

If the pressure is not correct, act on the knob of the pressure reducer (R) (see chapter 1.3.).

6.1. Adjustment

6.1.1. Control panel

The machine is fitted with a control panel, from which all programming and operation functions can be set.

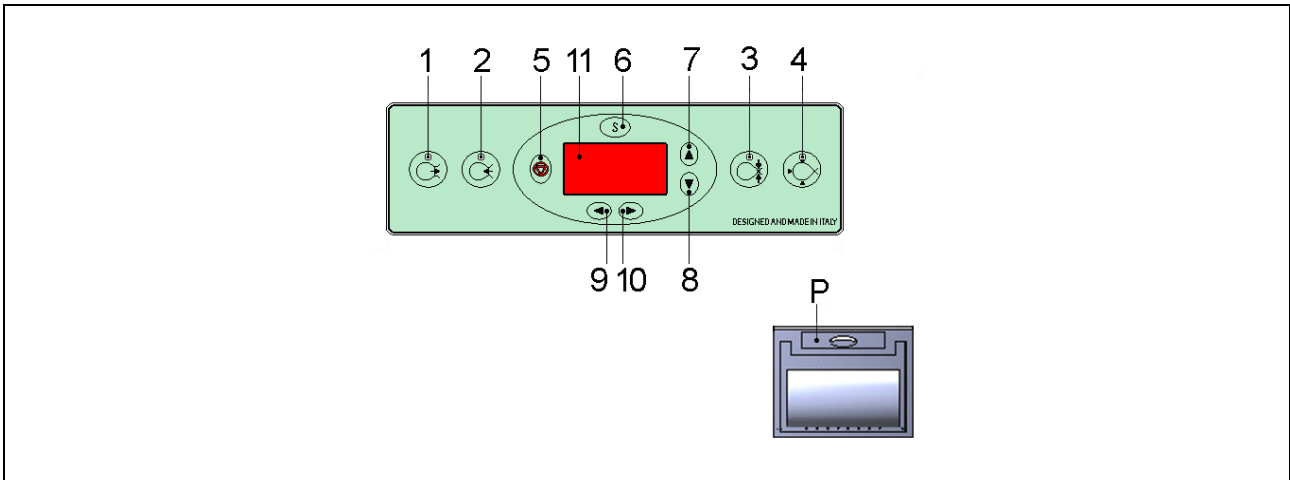

- P: Label printer
- 1: Led for vacuum and extra vacuum function
- 2: Led for gas function
- 3: Led for sealing function
- 4: Led for air re-immission function
- 5: Stop button
- 6: Confirmation button
- 7: Selection button
- 8: Selection button
- 9: Setting button
- 10: Setting button
- 11: Display

6.1.2. Switching the machine on

Set the main switch, located on the rear of the machine, to ON.

The display screen switches on and after the Minipack-torre logo, the following display page appears:



If the language to be set is different from that displayed, press the button (▶) and select the required language. Wait for the next display page "CONFIGURATIONS" and the main display page shown below to scroll.

If instead the language is correct, wait for the main display page to appear.

▲	PROGRAM:	→	displays the active program no. (P01÷P10).
	Time:	→	displays the sealing time set.
	Vacuum limit:	→	displays the degree of vacuum required inside the pack.
	Vacuum:	→	displays the "vacuum state" in the packaging chamber during the vacuum stage.
▼	Residual:	→	displays the difference between the set vacuum limit and the current level.
	Extra-vacuum:	→	indicates how long the pump continues to extract air from inside the bell after the machine has achieved the set vacuum level.
	Gas ratio:	↘	displays the percentage of gas inside the package.

To switch from one function to another, press the adjustment buttons (▲) and (▼).

The selected function is dimmed; at this point, to change the settings, press the buttons (▶) and (◀).



Before starting to pack, the program must be selected and the variable must be set according to the product to be packed. To do this, follow the instructions provided below.

6.1.3. Program selection and variable setting

6.1.3.1. Main display page (page one)

PROGRAM:	P02
Time:	
Vacuum limit:	
Vacuum:	
Residual:	
Extra-vacuum:	
Gas ratio:	

Press the buttons (▶) and (◀) to select the “**Program**” (e.g. P02).

PROGRAM:	P02
Time:	0.2 sec
Vacuum limit:	
Vacuum:	
Residual:	
Extra-vacuum:	
Gas ratio:	

Press the button (▼) to switch to the “**Time**” sealing function.
Press the buttons (▶) and (◀) to set the “Sealing time” (0.0 ÷ 4).
For the first work cycles, it is best to set a sealing time of about 1.5 seconds, and then lower it, so as to prevent burning the Teflon tape.

PROGRAM:	P02
Time:	0.2 sec
Vacuum limit:	100.0%
Vacuum:	
Residual:	
Extra-vacuum:	
Gas ratio:	

Press the button (▼) to switch to “**Vacuum limit**” function.
Press the buttons (▶) and (◀) to set the required vacuum limit (000.0 ÷ 100.0).
The recommended vacuum value is 100.0.

PROGRAM:	P02
Time:	0.2 sec
Vacuum limit:	100.0%
Vacuum:	000.0%
Residual:	
Extra-vacuum:	
Gas ratio:	

Press the button (▼) to switch to the “**Vacuum**” function.
By pressing the buttons (▶) and (◀) the vacuum setting can be displayed. This is achieved in 2 ways:

- 000.0%: displays the percentage of vacuum achieved inside the tank (100% corresponds to max vacuum achieved).
- 1000mbar: displays the pressure inside the tank (0mbar corresponds to the max vacuum achieved).

PROGRAM:	P02
Time:	0.2 sec
Vacuum limit:	100.0%
Vacuum:	000.0%
Residual:	100.0%
Extra-vacuum:	
Gas ratio:	

The value of the “**Residual**” function cannot be modified.
Displays the difference between set vacuum limit and the current limit during the packaging phase.

PROGRAM:	P02
Time:	0.2 sec
Vacuum limit:	100.0%
Vacuum:	X=45 000.0%
Residual:	100.0%
Extra-vacuum:	45 sec
Gas ratio:	

Press the button (▼) to switch to the “**Extra-vacuum**” function.
Press the buttons (▶) and (◀) to set the “**Extra-vacuum**” time (0 ÷ 45 seconds) only with “Vacuum limit” of 100.0.
This is the time the pump continues to extract air from inside the bell after the machine has achieved the set vacuum level.
The letter X followed by the extravacuum time in seconds is displayed next to “Vacuum”.
This function is useful for porous products in which air extraction is particularly difficult (e.g.: meat).

PROGRAM:	P02
Time:	0.2 sec
Vacuum limit:	100.0%
Vacuum:	000.0%
Residual:	100.0%
Extra-vacuum:	00 sec
Gas ratio:	000.0%

Press the button (▼) to switch to “**Gas rate**” function. A value can be set from 0 to 40%.
This value represents the percentage of gas inside the pack.
After the gas introduction phase, a residual vacuum can remain of min 60%.
Note: the gas value can be increased by means of a password (contact the supplier).
This change is only possible by applying an external compressor.
If the gas LED (2) flashes this means the gas tank is not correctly connected or the pressure is too low and the machine fails to start. Restore the correct connection.

Now press the (▼) to access the next page.

6.1.3.2. Main display page (page two)

N.B.: it is also possible to access the second page from the first page, or vice versa, by pressing the button (S).

PROGRAM: P02
Type: Cold cuts
 Package nr.:
 Expiry date:
 Gas type:
 VE SA CP AS SI IC LT

Press the button (▼) to switch to the “Type” function where the product to be packed can be selected.

For the list of products see the Note 01.

CATEGORY SELECTION
Cat.: Cold cuts
 Type:
 INGREDIENTS
 Price:
 Batch:
 Fact.:



CATEGORY SELECTION
Cat.: Baked products
 Type: Baked products
 INGREDIENTS
 Price:
 Batch:
 Fact.:



CATEGORY SELECTION
 Cat.: Baked products
 Type: **Bread**
 INGREDIENTS
 Price:
 Batch:
 Fact.:



Press the button (S) to display the list of the categories of available products. The selection display page now appears.

Press the buttons (►) and (◀) to select the chosen Category, e.g., “Baked products”.

Press the button (▼) to select the type of product and the buttons (►) and (◀) to select from the available list e.g. “Bread”.

CATEGORY SELECTION
 Cat.: Baked products
 Type: Bread
INGREDIENTS
 Price:
 Batch:
 Fact.:



EDIT INGREDIENTS
 INGREDIENTS: FLOUR,
 WATER, YEAST

Press the button (▼) to switch to the “INGREDIENTS” function that enables the operator to enter/view the product components. Press the button (S) .

This opens the “EDIT INGREDIENTS” page where the operator can enter the required text (see instructions in chap. 6.1.3.4.). Press the button (S) to confirm the ingredients and return to the “CATEGORY SELECTION” page.

Note 01: for the list of the categories and types of products that can be chosen, see the following chart.

Category	Type
Vegetables	Lettuce, Tomatoes, Broccoli
Fruits	Apples, Apricots, Blueberries, Pears, Peaches, Strawberries
Fish	Fish, Smoked fish, Cod, Herring, Salmon, Trout, Shrimps, Sea fruits
Dairy product	Cheese, Grated cheese, Ricotta cheese, Yoghurt, Cream, Powdered milk
Red meat	Beef, Pork, Veal, Lamb, Minced meat
Poultry	Chicken, Cooked chicken, Turkey, Duck
Cold cuts	Sliced cooked ham, Parma ham, Salami, Mortadella, Frankfurters, Sausage
Baked products	Bread, Pizza, Croissant
Delicatessen	Lasagna, Ravioli, Sandwiches, Fresh pasta
Dried food	Coffee, Hazelnuts, Potato chips
Pers. ingredients	Pers. ingredients

In addition to the products already present in the list, it is possible enter a further 20 personalised products. The procedure indicated below explains how to do this.

CATEGORY SELECTION
 Cat.: **Pers. ingredients**
 Type:
 INGREDIENTS
 Price:
 Batch:
 Fact.:

Select
 "Pers. ingredients".



CATEGORY SELECTION
 Cat.: Pers. ingredients
 Type: **001**
 INGREDIENTS
 Price:
 Batch:
 Fact.:

Press the button (▼) to switch to
 the "Type" function.



EDIT DISH
Olives

Press the button (S) and enter the
 personalised product (e.g.: Olive).
 Press the (S) button to confirm and
 return to the "CATEGORY
 SELECTION" page



CATEGORY SELECTION
 Cat.: Pers. ingredients
 Type: Olives
 INGREDIENTS
 Price: **5 EURO**
 Batch:
 Fact.:

Press the button (▼) to switch to
 the "Price" function.
 Type in the price of the package
 (see instructions in chap. 6.1.3.4.).



CATEGORY SELECTION
 Cat.: Pers. ingredients
 Type: Olives
 INGREDIENTS
 Price: 5 EURO
 Batch: **10 2010**
 Fact.:

Press the button (▼) to switch to
 the "Batch" function.
 Type in the packaging batch date.



CATEGORY SELECTION
 Cat.: Pers. ingredients
 Type: Olives
 INGREDIENTS
 Price: 5 EURO
 Batch: 10 2010
 Fact.: **Name**

Now press the button (▼) and enter
 the producer's name.
 Press the button (S) to return to the
 main display page.



PROGRAM: P02
 Type: Cold cuts
 Package nr.: **100**
 Expiry date:
 Gas type:
 VE SA CP AS SI IC LT

Press the button (▼) to switch to "**Package nr.**" function.
 The package number corresponds to the number of products packaged using the
 currently active program (e.g. P02).
 To zero this number press the (▶) and (◀) buttons simultaneously.

PROGRAM: P02
 Type: Cold cuts
 Package nr.: 100
 Expiry date: **21/01/2011**
 Gas type:
 VE SA CP AS SI IC LT

Press the button (▼) to switch to "**Expiry date**" function.
 Set the expiry date (see instructions in chap. 6.1.3.4.).

PROGRAM: P02
 Type: Cold cuts
 Package nr.: 100
 Expiry date: 21/01/2011
 Gas type: **FOOD00**
 VE SA CP AS SI IC LT

Press the button (▼) to switch to "**Gas type**" function.
 A **FOOD** value can be set (gas tank) from **1** to **10** by
 pressing the buttons (▶) and (◀).
 By pressing the button (S) the display page is opened
 relating to gas tank composition.

FOOD: **01**
 O2: 000
 CO2: 000
 N2: 000

On this display page, those who so require can set and
 therefore store the oxygen (O2), carbon dioxide (CO2)
 and nitrogen (N2) values making up this tank e.g. **01**.
 Press the button (S) to return to the previous display
 page.

PROGRAM: P02
 Type: Cold cuts
 Package nr.: 100
 Expiry date: 21/01/2011
 Gas type: FOOD00

VE SA CP AS SI IC LT
 X

Press the button (▼) to switch to “Advanced functions”.

VE: Outside vacuum
 SA: Soft Air
 CP: Condition Program
 AS: Auto Seal Program
 SI: Sealing
 IC: Infusion cycle
 LT: Liquid time

Now press the buttons (▼) and (▲) to select the function.

Press the button (▶) to activate the function (X appears) and (◀) to deactivate it.

VE “Outside vacuum”

This function allows obtaining the vacuum in special containers with a pipe directly to the packaging tank. The function does not include the pack sealing phase.

PROGRAM: P02
 Time: 0.2 sec
 Vacuum limit: 100.0%
 Vacuum: 000.0%
 Residual: 100.0%
 Extra-vacuum: 00 sec
 Gas ratio: 000.0%

START

If activated press the button (S), followed by the (▼) button in order to select **START** and start the cycle by pressing the button (S).

SA “Soft Air”

This function allows regulating the speed of air return into the tank, preventing uncontrolled movements of the packs (1 = minimum speed; 4 = top speed).

If enabled press the button (S) and select required speed. Press the Stop button (5) to confirm.

Note: If the function is active, but the lid fails to open at the end of the cycle, switch the machine off then on again, or wait 50 seconds until the lid reopens. Check that the Soft Air valve has been installed correctly.

CP “Condition Program”

After a period of inactivity of the machine (at least 15 days) or after packaging products containing liquid products, it may be necessary to eliminate liquid emulsion from the hydraulic fluid of the pump.

The problem that could arise concerns too much remaining air, or an interruption of the vacuum cycle due to having exceeded the suctioning time.

If enabled press the button (S) to start an operating cycle lasting 4 minutes.

AS “Auto Seal Program”

The function envisages a packaging cycle with a fixed time irrespective of the vacuum level that has been reached, defined beforehand. The basic time of the complete cycle is 25 seconds. The default increment is 4 seconds, however it is possible to set up an increment time of between 0 to 8 seconds (corresponding to a base time of 25 + an increment of 8 = 33 seconds).

This function is suitable for packaging products with excessive humid part.

By selecting this function, the operation of the machine remains basic. The only parameter that can be changed is the ON time.

SI “Sealing”

The function envisages a packaging cycle with 60% max vacuum percentage. By selecting this function, machine operation remains basic. The only parameter that can be changed is the sealing time.

IC “Infusion cycle”

This function can be used to carry out packaging procedures with delay that can be varied from 0.5 to 10 minutes between the vacuum and sealing phases (ideal for marinated food products). After the delay, the cycle restarts, restoring the set vacuum level if necessary.

Press the (S) button and set up the delay time using the (▶) and (◀) buttons. Press the (S) button to confirm and return to the previous page.

LT “Liquid time”

This function can be used to package pouches automatically with liquid products.

Press the (S) button and set up the function using the (▶) and (◀) buttons, selecting the desired level from 1 to 10 (1 for cold products; 10 for hot products). Press the (S) button to confirm and return to the previous page.

The packaging cycle may also be interrupted by pressing the Stop (5) button.

6.1.3.3. CONFIGURATIONS display page

To display the CONFIGURATIONS page press the Stop button (5) and the selection buttons (▼) and (▲) at the same time for 5 seconds.

CONFIGURATIONS	
Date: 15/04/10 21.57	→ Date and time
Operator: 0000	→ Operator code
Label : NO	→ Label printing option
-> CALIBRATE	→ CALIBRATE function
-> SERVICE	→ SERVICE function
-> DIAGNOSTIC	→ DIAGNOSTIC function

CONFIGURATIONS	
Date: 15/04/10 21.57	Press the buttons (▼) and (▲) to select the day, month, year and time.
Operator: 0000	Once the day, month, year and time have been evidenced, press the buttons (▶) and (◀) to set the required dates.
Label : NO	
-> CALIBRATE	
-> SERVICE	
-> DIAGNOSTIC	

CONFIGURATIONS	
Date: 15/04/10 21.57	
Operator: 0000	Press the button (▼) to switch to “Operator” function.
Label : NO	Set (if necessary) the dedicated packaging operator code using the same buttons as for the “Date” function.
-> CALIBRATE	
-> SERVICE	
-> DIAGNOSTIC	

CONFIGURATIONS	
Date: 15/04/10 21.57	
Operator: 0000	
Label : NO	Press the button (▼) to switch to “Label” function
-> CALIBRATE	Press the buttons (▶) and (◀) to set the choice:
-> SERVICE	<ul style="list-style-type: none"> ▪ NO: do not print label. ▪ 001 ÷ 008: number of labels to be printed at the end of the packaging cycle.
-> DIAGNOSTIC	

CONFIGURATIONS	
Date: 15/04/10 21.57	
Operator: 0000	
Label : NO	
-> CALIBRATE	Press the button (▼) to switch to “CALIBRATE” function.
-> SERVICE	Press the button (S) and lower the lid to start the calibration phase.
-> DIAGNOSTIC	The display (11) unit shows a decreasing number.
	When 000mbar is reached, press the Stop button (5) to end calibration.
	The lid opens automatically.

CONFIGURATIONS	
Date: 15/04/10 21.57	
Operator: 0000	
Label : NO	
-> CALIBRATE	
-> SERVICE	Press the button (▼) to switch to “SERVICE” function.
-> DIAGNOSTIC	Press the button (S) and enter (if required) the phone number and address of technical assistance.
	Note: the first available line is numerical, while the second is alphanumeric.
	The phone number and address appear every time an alarm trips

CONFIGURATIONS	
Date: 15/04/10 21.57	
Operator: 0000	
Label : NO	
-> CALIBRATE	
-> SERVICE	
-> DIAGNOSTIC	Press the button (▼) to switch to “DIAGNOSTIC” function.
	Press the button (S) and enter the password D45U .
	Press the button (S) again.

DIAGNOSTIC MENU

- > **UTILITY**
- > STATUS
- > ALARMS
- > OUTPUTS
- > INPUTS

Press the button (S).

UTILITY

Config. Lock: NO

-> RESET TO DEFAULT

NO: the configuration is not blocked. All set parameters can be changed.
 YES: the configuration is blocked. None of the parameters can be changed.

Allows restoring default values

Once the parameters have been changed press the stop button (5) to return to the DIAGNOSTIC MENU.

DIAGNOSTIC MENU

- > UTILITY
- > **STATUS**
- > ALARMS
- > OUTPUTS
- > INPUTS

Press the button (▼) to switch to STATUS function. Now press the button (S).

STATUS

Cycles: **000000**

Oil: 12000

Stop: 000000

On time: 000000

Cycle time: 000000

Warranty: 01/01/11

The following are displayed:

Total number of cycles performed by machine.
 Number of cycles after which the OIL alarm trips.
 Number of cycles after which the machine can be blocked.
 Total number of hours of activity of machine.
 Total number of machine cycle hours.
 End of machine warranty.

Press the stop button (5) to return to the DIAGNOSTIC MENU.

DIAGNOSTIC MENU

- > UTILITY
- > STATUS
- > **ALARMS**
- > OUTPUTS
- > INPUTS

Press the button (▼) to switch to ALARMS function. Now press the button (S).

ALARM

Gas pressure: OK

Vacuum time: OK

Soldering time: OK

Pump time: OK

The state of the alarms is displayed:

OK: Correct operation
 AL: Alarm tripped due to fault.

Press the stop button (5) to return to the DIAGNOSTIC MENU.

DIAGNOSTIC MENU

- > UTILITY
- > STATUS
- > ALARMS
- > **OUTPUTS**
- > INPUTS

Press the button (▼) to switch to OUTPUT function. Now press the button (S).

OUTPUT

Vacuum valve: [█]

Air valve: []

Gas valve: []

Soldering valve: []

Soft-air valve: []

Vacuum pump: []

The correct operation of the outputs can be checked as follows:

Using the buttons (▼) and (▲) position the cursor on each output and press the button (▶). [█] appears and, if correctly operating, you will hear the contact of the diagnosed output open. Press the button (◀) to close the contact.

Press the stop button (5) to return to the DIAGNOSTIC MENU.

DIAGNOSTIC MENU

- > UTILITY
- > STATUS
- > ALARMS
- > OUTPUTS
- > **INPUTS**

Press the button (▼) to switch to INPUTS function. Now press the button (S).

INPUT

Microswitch: OFF

Pressure switch: OFF

The correct operation of the inputs can be checked as follows:

Press the lid micro contact and/or disconnect the pressure switch.

6.1.3.4. How to enter and modify text

- In order to enter and/or modify text in any field on the display (11), use the (▼) and (▲) buttons to select the position of the character to be entered. Once the position has been highlighted, press the (▶) and (◀) buttons to select the desired character.
- To cancel a line of text completely, position the cursor over any character in the text to be deleted and press the (▶) and (◀) buttons simultaneously.

6.1.3.5. Setting up label data

If you set up a value between 001 and 008 in the “Label” function in **CONFIGURATIONS** (see instructions in chap. 6.1.3.3.), at the end of each cycle the printer will print the number of labels that corresponds to this value. The label can be customised by entering various data as explained below. Some of these data may be displayed or hidden, depending on the settings.

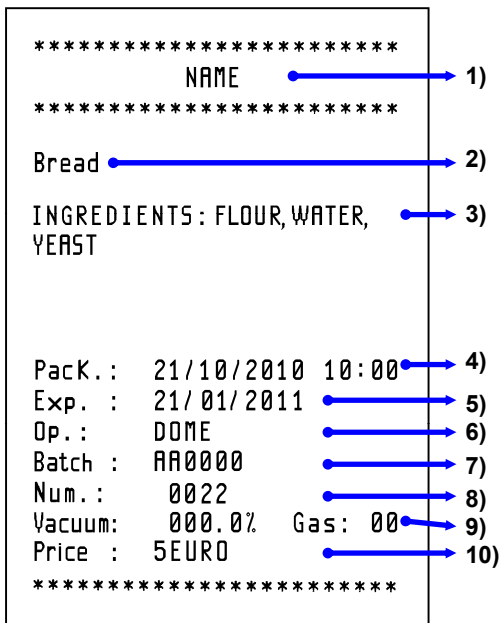

- 1) Manufacturer's name set up in the function on the “CATEGORY SELECTION” page.
To avoid displaying the name, leave this field empty.
- 2) Packaged product set up in the “Type” function on the “CATEGORY SELECTION” page.
To avoid displaying the product type, select the “Per. Ingredients” on the “CATEGORY SELECTION” page and leave the “Type” field empty.
- 3) Ingredients of the packaged product (or any other text) set up in the “INGREDIENTS” function on the “CATEGORY SELECTION” page.
To avoid displaying the ingredients, leave this field empty.
- 4) Packaging date and time set up in the “Date” function on the “CONFIGURATIONS” page.
- 5) Product expiry date set up in the “Expiry date” function on the second page of the main page.
- 6) Name or code of the operator who carried out the packaging cycle set up in the “Operator” function on the “CONFIGURATIONS” page.
- 7) Packaging batch of the packaged product set up in the “Batch” function on the “CONFIGURATIONS” page.
- 8) Number of packages produced using the selected program (e.g.. P01).
- 9) Percentage of vacuum and gas set up in the “Vacuum limit” and “Gas ratio” function on the first page of the main page.
- 10) Package price set up in the “Price” function on the “CATEGORY SELECTION” page
To avoid displaying the price, leave this field empty.

6.2. Packaging

After selecting the program and setting the necessary variables, go ahead with packaging.

Place the product to be packaged inside the pouch.

Place the pouch inside the tank and on the sealing bar in a way as linear as possible.

Try to prevent the pouch from wrinkling. Wrinkles might negatively affect the hermetic seal formed by sealing. Pouches shall be at least 2cm beyond the sealing.

If the "GAS" function is on, the pouch must be positioned with the strip open on the gas nozzle on one side of the sealing bar.

Close the upper Plexiglas cover.

The packaging cycle starts when the cover is closed.

Note: When the product dimensions allow, we recommend using some tables (13) as shimming the product facilitates positioning the pouch in relation to the sealing bar.

Moreover, it allows decreasing the volume of the tank (14) and, therefore, the amount of air to be removed, speeding up the packaging cycle.

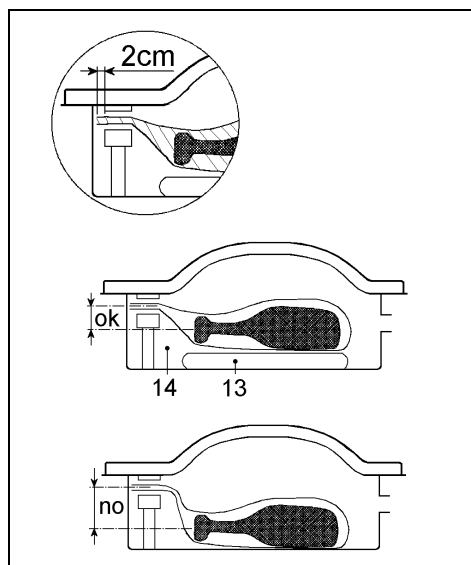

The packaging cycle is sub-divided into four phases:

1. Suction phase during which all the air contained inside the tank and the pouch is sucked.
The LED is on (1).
2. Gas injection phase (if the machine is equipped with a gas plant).
The LED is on (2).
3. Sealing phase during which the packet is sealed.
The LED is on (3).
4. Air re-enter phase and subsequent opening of the cover.
The LED is on (4).
The tank will reach its atmospheric pressure and the upper cover will open again.
Machine is ready for a new packing cycle.

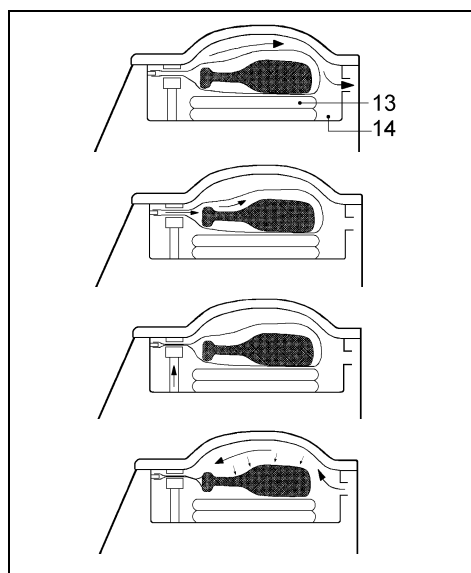

If you press the Stop button (5), the machine will immediately stop sucking and automatically start sealing the pouch. This function will be used to pack liquid and hot products which may start boiling during the vacuum cycle.

6.3. Alarm messages

The electronic board detects a series of alarms that are indicated by the following messages, which appear on the display (11):

- | | |
|-----------------------|---|
| OIL | Check the level and colour of the oil, as described in the pump manual.
To reset this alarm, press button (S). |
| STOP | The electronic board is blocked. Contact the technical service department. |
| PRESSURE | A fault has occurred in the gas introduction system.
Make sure the gas tank is correctly connected to the machine.
To reset this alarm, switch the machine off and on again. |
| VACUUM TIME | The machine did not generate the vacuum within the defined maximum time (90 seconds).
Check that the cover is closed correctly.
To reset this alarm, switch the machine off and on again. |
| SOLDERING TIME | The machine has exceeded max time provided for the sealing phase (4 seconds).
To reset this alarm, switch the machine off and on again. |

7.1. Precautions for ordinary maintenance interventions

ORDINARY MAINTENANCE, MUST BE EXECUTED BY QUALIFIED STAFF APPROPRIATELY TRAINED.



Before any routine maintenance switch the machine off by acting on the main switch and remove the plug from the mains socket.
Disconnect gas plant.

7.2. Cleaning of the sealing bar

Use a dry cloth to remove any film residue on the sealing bar (16).

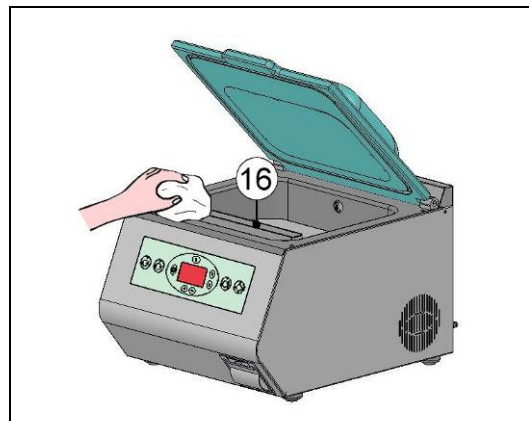

7.3. Replacement of the Teflon and the sealing blade

Before replacing Teflon and the sealing blade wait for the machine to be properly cooled.

- Remove the sealing bar (16) from its seat
- Remove the Teflon adhesive tape
- Unscrew the nuts fastening the blades to each end of the sealing bar
- Tighten the new blades. Make sure they are taut enough before blocking them
- Use the Teflon adhesive tape to cover the sealing blades
- Place the sealing bar into its seat.

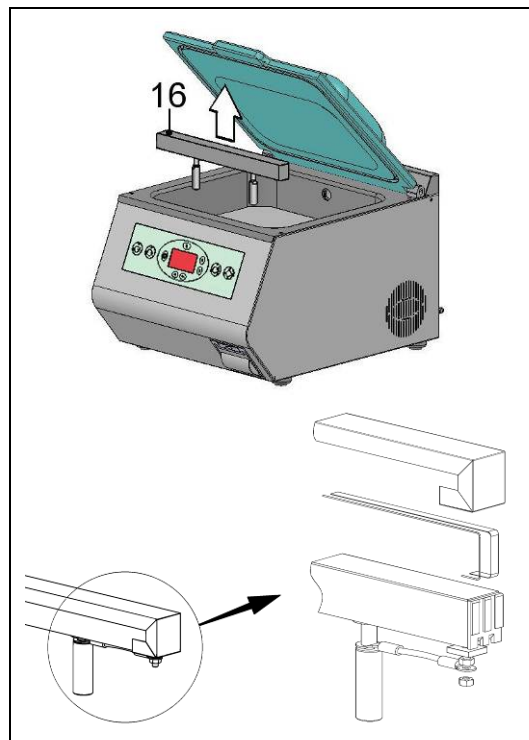

7.4. Replacement of the cover gasket

When the cover gasket (17) is worn out, replace it.

This will improve the efficiency of the machine and increase its speed rate. Replacement is very easy. After having removed the gasket which has worn out, clean its seat and insert the new gasket in a linear way. Make sure its ends are joined. Leave no opening which might prevent the product from being properly vacuum-packed.

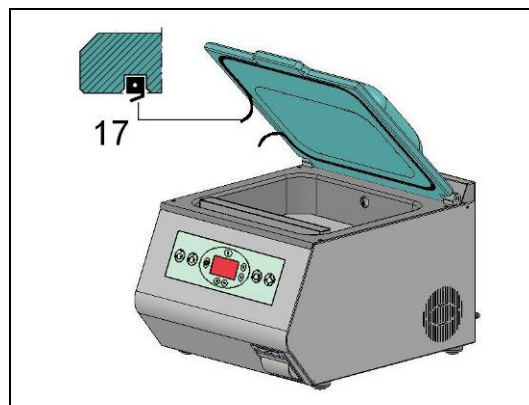

7.5. Cleaning machine

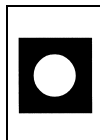

To clean the Plexiglas cover (18), clean both the outer and the inner side with water and soap only. Never use detergents or solvents which might damage the cover (18) and reduce its transparency as well as its resistance.

Check the state of the cover on a regular basis, it must in good condition, completely clean, and must not display any yellowing or increase in opacity. If any of the above defects are observed, replace the cover.



The Plexiglas cover must be replaced ever 10 years!

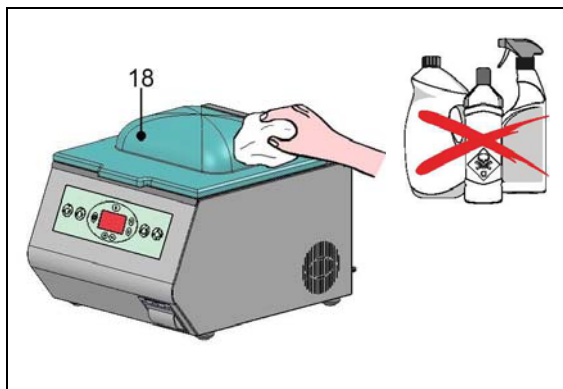

Use normal detergents for stainless steel to clean the case and the internal tank.

Do not use chlorine-based detergents (hydrochloric acid, sodium hypochlorite, etc.), even if diluted. Do not use abrasive agents, metal wool or any abrasive sponge to clean the surfaces.

Do not use detergents for silver.

Do not clean the machine using water jet or vapour.

7.6. Vacuum pump maintenance

It is very important to regularly service the pump to ensure extended and correct operation.

For any maintenance operation, eg level and oil quality check, oil and filter replacement, cleaning, etc., comply with the instructions indicated on the pump manual.

7.6.1. Condition Program

As already described at chapter 6.1.3.2., this program ensures a complete rinse of the pump, eliminating any liquid emulsion that could form in the oil.

It is also advisable to run the program before using the machine for the first time, after the machine has been stationary for a lengthy period of time, and especially prior to changing oil.

7.7. Problem solving

PROBLEM	CAUSE	SOLUTION
The pouch is not sealed correctly	<ul style="list-style-type: none"> The sealing time is not correct. The cover gasket is dirty or worn. The pouch is not placed correctly on the sealing bar. The sealing bar is worn (the Teflon coating is burnt). The blade placed under the Teflon of the sealing bar is broken. 	<ul style="list-style-type: none"> Change the sealing time. Clean or replace the cover gasket (contact the Technical Assistance Service for a replacement). Position the pouch correctly. Replace the sealing bar (contact the Technical Assistance Service for a replacement). Replace the blade (contact the Technical Assistance Service for a replacement).
Final vacuum is poor	<ul style="list-style-type: none"> The set vacuum percentage is incorrect. The cover gasket is dirty or worn. The cover is not closed correctly. 	<ul style="list-style-type: none"> Change the vacuum percentage. Clean or replace the cover gasket (contact the Technical Assistance Service for a replacement). Close the cover correctly. Make sure that objects or dirt are not found between the cover and tank.
The cover does not open	<ul style="list-style-type: none"> No power supply. 	<ul style="list-style-type: none"> Wait until the power supply is restored.

If the machine does not work properly after the above-mentioned checks, contact the assistance service describing the detected defect.

7.8. Wiring diagram (page 82, 83).

B0	Cycle start limit switch
B1	Gas pressure switch
C1	Vacuum pump condenser
ER1	Sealing blade
K1	Control board
F1	Fuse
F2	Fuse
QF1	Thermal
QF2	Thermal
M1	Vacuum pump motor
P1	Printer
Q1	Main switch
QM1	Motor contactor
QM2	Blade heater contactor
QV1	Air re-immission valve
QV2	Gas injection airvalve
QV3	Sealing airvalve
S1	Membrane keyboard
T1	Sealing transformer
T2	Auxiliary transformer
X1	Power supply plug
X2	Printer connector

7.9. Pneumatic diagram (page 84).

CV	Vacuum hood
UG	Gas nozzles
BA	Suction pipe union
QV1	Air re-immission valve
QV2	Gas injection airvalve
QV3	Sealing airvalve
B1	Gas pressure switch
BG	Gas cylinder
MP	Pneumatic membrane
M1	Vacuum pump motor
PV	Vacuum pump
S	Sensor

7.10. Disassembling, demolition and elimination of residuals**ATTENTION!**

All operations about disassembling and demolition must be done by qualified personnel with mechanical and electrical expertise required to work in security conditions.

Proceed as follows:

- disconnect machine from power mains
- disconnect the machine from the gas system (if installed)
- disassemble components
- drain the oil from the pump.

All wastes must be treated, eliminated or recycled according to their classification and to the procedures in force established by the laws in force in the country the equipment has been installed.



The symbol indicates that this product shall **not** be treated as household waste.

By assuring that the product will be properly disposed of, you will facilitate the prevention of potential negative effects for the environment and the man's health, which might be otherwise caused by the improper waste treatment of this product.

For more detailed information about the recycling of this product, please contact the product seller or, as an alternative, the after-sales service or the corresponding waste treatment service.

Chapter 8. Guarantee**8.1. Certificate of guarantee**

The guarantee runs for 12 months after the installation date under the conditions set forth on the instruction manual.

Fill in the card with all data requested, tear out along the perforations and send in.

8.2. Guarantee conditions

The guarantee runs for 12 months and goes into force on the installation date of the machine. The guarantee covers free replacement or repair of any parts due to defects arising from faulty material. The repairs or replacement are usually carried out at the manufactures, with transport or workmanship at buyer's charge. If the repair or replacement is carried out at the buyer's place, he shall bear the travelling, transfer and workmanship charges. Work under guarantee can be carried out exclusively by the manufacturer or by the authorised dealer. In order to be entitled to repairs under the guarantee, the faulty part must be sent for repair or replacement to the manufacturer or his authorised dealer. The return of such repaired or replaced part will be considered to be the performance of the guarantee.

The guarantee is voided:

- in case of failure to mail the CERTIFICATE OF GUARANTEE, duly filled in and signed, with in 20 days after the date of purchase
- in case of inappropriate installation, power supply, misuse and mishandling by unauthorised persons
- in case of changes made to the machine without prior agreement in writing by the manufacturers
- if the machine is no longer the property of the first buyer.

The manufacturer decline any responsibility for damage to persons or things in case of inappropriate installation or connection to the power mains or omission of connection to earth or in case of any mishandling of the machine.

The manufacturer undertake to carry out any variations and changes made necessary by technical and operating requirements.

**IN THE EVENT OF DISPUTES THE COURT OF BERGAMO (ITALY)
SHALL HAVE SOLE JURISDICTION.**

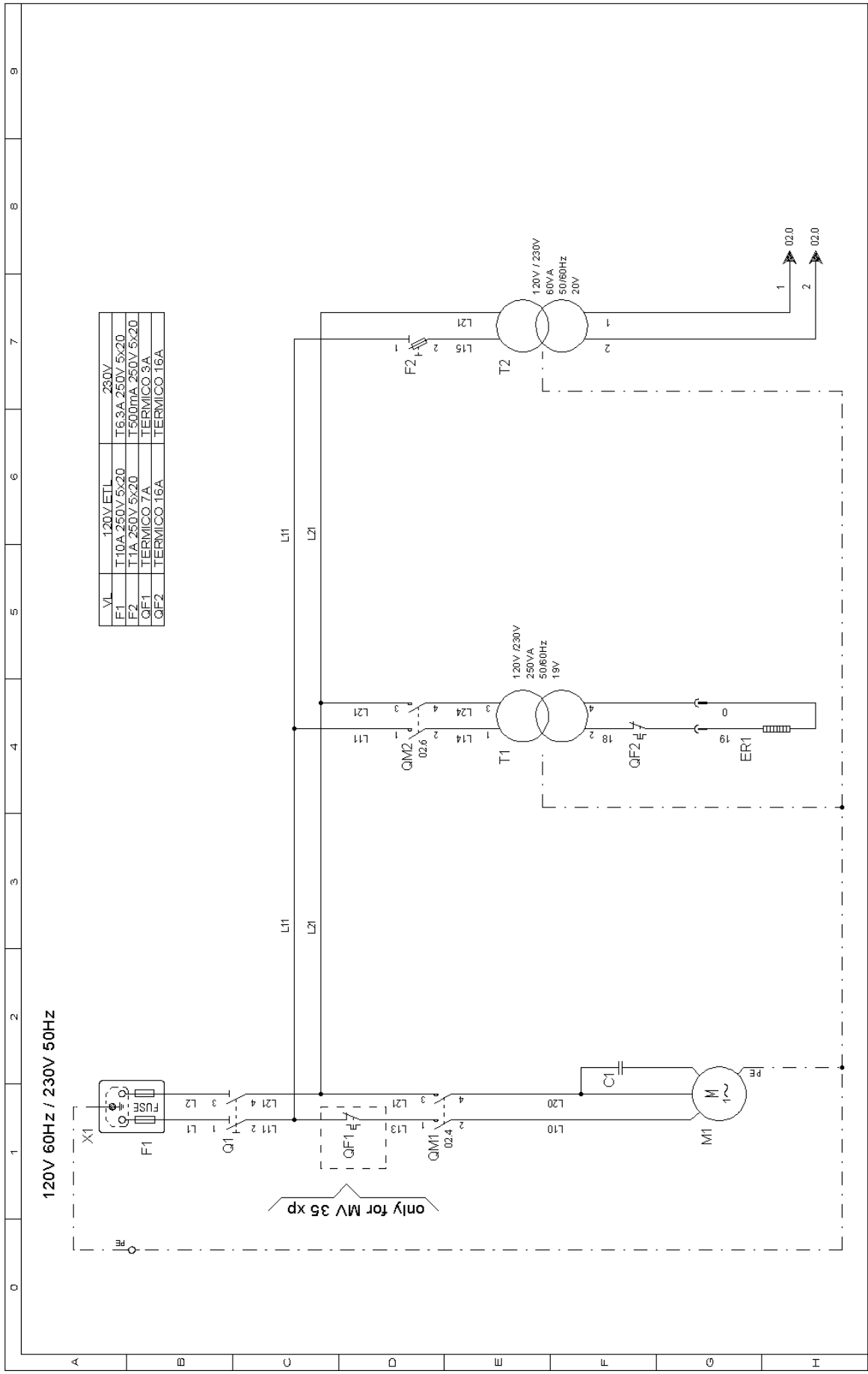

VL	120V/ETL	230V
F1	T10A 250V 5x20	T6.3A 250V 5x20
F2	T1A 250V 5x20	T500mA 250V 5x20
QF1	TERMICO 7A	TERMICO 3A
QF2	TERMICO 16A	TERMICO 16A

PROGETTO:	MV31XP/MV35XP	FOGLIO	01
CODICE:	MV31E35/MV35E35	DI	02
DISEGNO NR:	WDMV3103		
TITOLO:	SCHEMA DI POTENZA		
DISEGNATORE:	Baldoni	DATA:	26/05/2011

MINIPACK - TORRE S.p.a.
 Via Provinciale, 54 - 24044 D'ALMINE (BG)
 Tel. +39 035-565525 Fax. +39 035-564945
 e-mail: info@minipack-torre.it - www.minipack-torre.it



REV.	DATA	FIRMA	MODIFICA

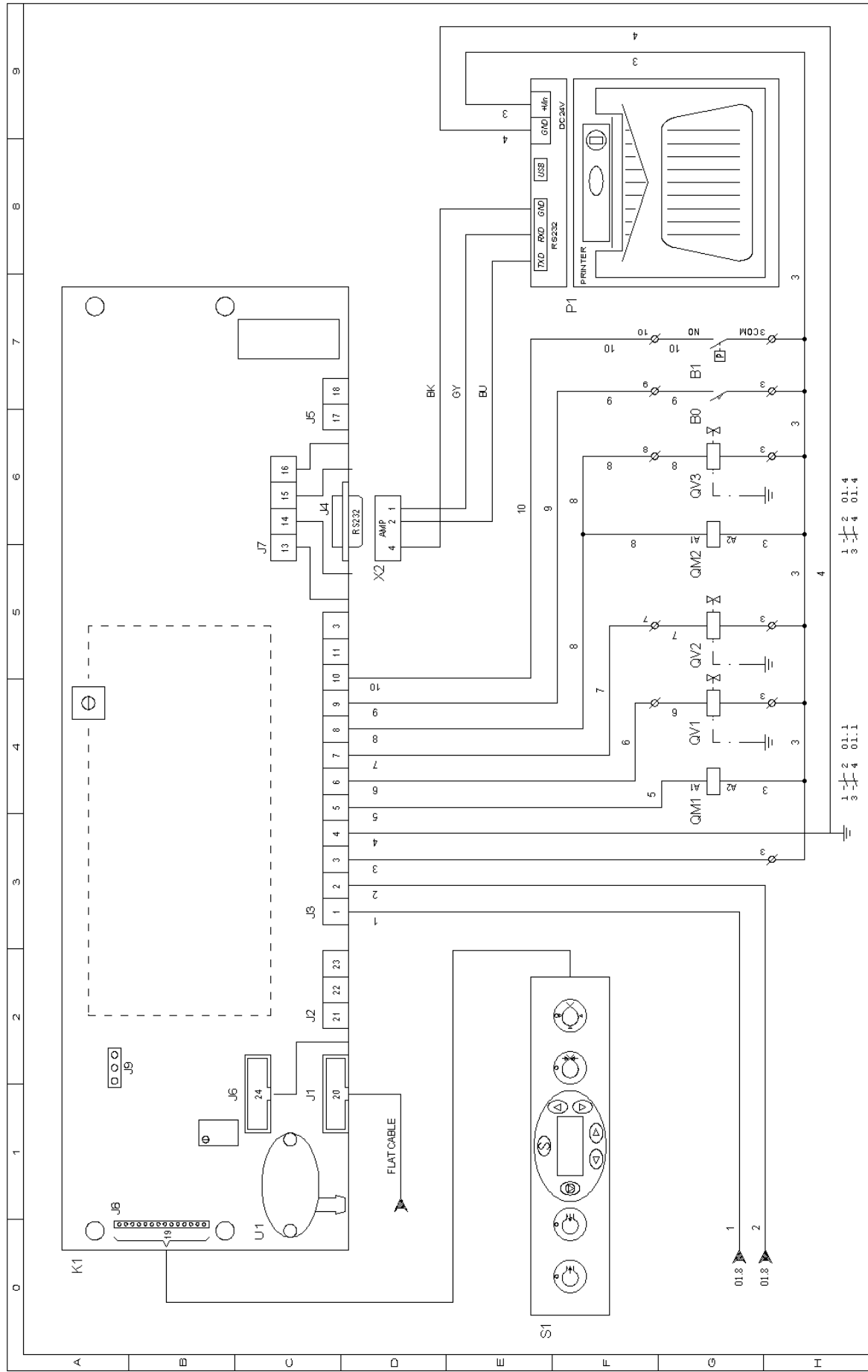

PROGETTO:	MV31XP/MV35XP	FOGLIO	02
CODICE:	MV31E35/MV35E35	DI	02
DISIGNO NR:	WDMV3103	SCHEMA DI COMANDO	
TITOLO:			
DISIGNATORE:	Baldoni	DATA:	26/05/2011

			
MINIPACK - TORRE S.p.a. Via Provinciale 54 - 24044 DALMINO (BG) Tel. +39 035 563525 Fax. +39 035 564945 e-mail: info@minipack-torre.it - www.minipack-torre.it			
REV.	DATA	FIRMA	MODIFICA

